

U12 SERIES ULTRA HIGH PURITY REGULATOR

U12 series single stage ultra high purity regulator is developed for the semiconductor industry, it is manufactured in accordance with SEMI requirement and assembled, tested and packaged in a class 100 clean room.



U12SLBK-DHP-VSM8-E

Features

- 316L or 316L VAR stainless steel body
- Metal to metal diaphragm to body seal
- Easy front panel and rear bracket mounting
- Gauge ports are standard with 1/4" face seal male. Internal 1/4" face seal female is also available
- Fully internal electropolished
- Cleaned, assembled, and packaged for high-purity semi-conductor applications
- High-cycle life
- 100% Helium-leak tested

Materials

- Body: 316L, 316L VAR
- Seat: PCTFE*, Vespel®
- Diaphragm: HC22



U12SLAK-DHW-VSF8-E

Specifications

- Max. Inlet Pressure: 500psi (35 bar), 3000psi (206 bar)
- Max. Outlet Pressure: 0~25psi (1.7 bar), 0~50psi (3 bar), 0~75psi (5.2 bar), 0~100psi (7bar), 0~150psi (10bar)
30" Hg Vac~30psi, 30" Hg Vac~60psi, 30" Hg Vac~100psi
- Temperature: -40°F ~ 165°F (-40°C ~ 74°C)
- Cv: 0.45
- Inboard leakage: 1×10^{-9} atm/sec He
- Across seat leakage: 4×10^{-8} atm/sec He
- Proof pressure: 150% of maximum rated pressure
- Burst pressure: 400% of maximum rated pressure
- Surface Finish: 15 uin, 10 uin
- Internal Volume: 17.4 cc

*: Standard material

Dimensions

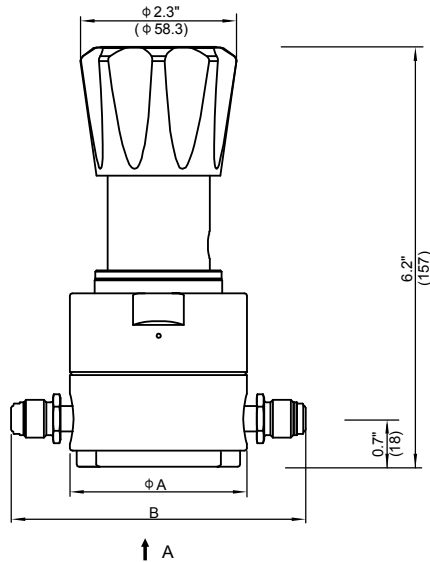

Connection Type	Dimension in.(mm)	
	A	B
VSF4	1/4" swivel female FSR	3.7" (94)
VSM4	1/4" swivel male FSR	4" (101.6)
VSF8	1/2" swivel female FSR	5.22" (132.6)
VSM8	1/2" swivel male FSR	5.22" (132.6)
TW6	3/8" weld stub	4" (101.6)
TW8	1/2" weld stub	4.34" (110.2)

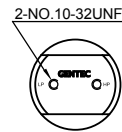

A

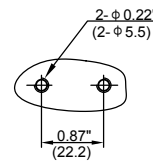

Rear bracket mounting

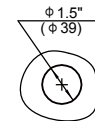

Front panel mounting
(Maximum thickness is 0.28")

Dimension: in.(mm)

Flow Data

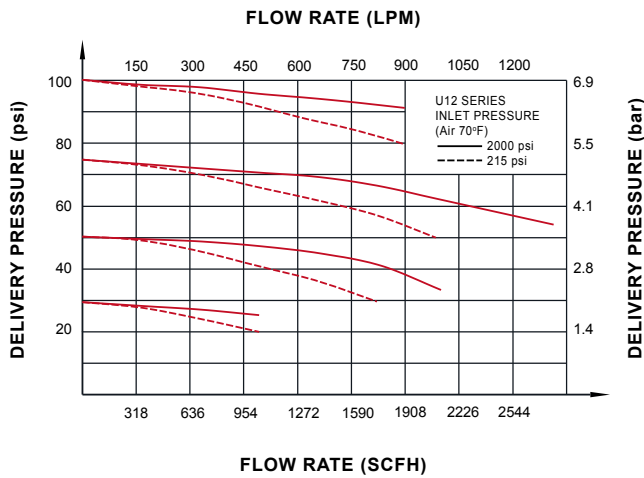

Regulator Port Configurations

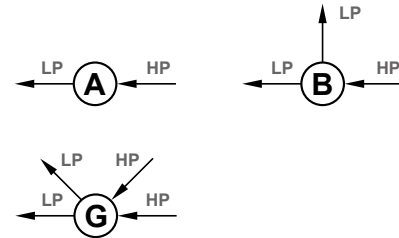

	Material Configuration		
	U12SL	U12SLV	U12SLV***-H
Body	316L	316L VAR	316L VAR
Diaphragm	HC-22	HC-22	HC-22
Stem	HC-22	HC-22	HC-22
Nozzle	316L	316L	HC-22
Seat	PCTFE (Vespel®)		
Surface	10µin (Standard)	10µin (Standard)	10µin (Standard)
Finish	25µin (Options)	7µin, 5µin (Options)	7µin, 5µin (Options)

Ordering Information

EX:	U12	SL	B	K	- D	I	P	- VSF4	- E	- H	- P
	Series	Body	Ports	Seat	Inlet Pressure	Outlet Pressure	Pressure Gauge	Inlet / Outlet Connection	Surface Finish	Corrosion Resistance	Options
	U12	SL: 316L SLV:316L VAR G	A B G	K: PCTFE V: Vespel®	D: 3000 psi F: 500 psi	H: 0 ~ 150 psi I: 0 ~ 100 psi J: 0 ~ 75 psi K: 0 ~ 50 psi L: 0 ~ 25 psi Q: 30" Hg Vac~30 psi R: 30" Hg Vac~60 psi S: 30" Hg Vac~100 psi	W: Without Gauge P: psi / bar Gauge K: psi / kPa Gauge	VSF4, VSM4 VSF8, VSM8 TW6, TW8	None: Ra 15 µin E: Ra 10 µin	None: 316L Nozzle and stem H: HC22 Nozzle and stem SH: HC22 stem	None: Rear Bracket Mounting P: Panel Mounting

